

Curved-Tooth Gear Couplings BOS II made from Polyamide/Sintered Metal

Material: Sleeve part: polyamide 6.6.
Hub parts: sintered metal, black oxide finish.

Bore tolerance H7 with keyways DIN 6885/1 and set screws (2 screws per hub).

Hubs with * are pre-bored, without keyway and without set screw threads.

Axial displacement = max. ± 2 mm per hub.
Angular displacement = max. $\pm 1^\circ$ per hub.
Radial displacement = max. 0.3 mm at 1500 min⁻¹.
The permissible displacement values are dependent on power and speed.

Temperature range: -40°C to +80°C,
short time up to +120°C.

All 3 parts have to be ordered separately.

Other sizes and bores on request.

Ordering Details: e.g. for coupling Size 14,
with bore 8mm and bore 10mm:

1 Item Product No. 607 614 08 Hub, size 14, bore 8mm
1 Item Product No. 607 614 10 Hub, size 14, bore 10mm
1 Item Product No. 607 614 00 Sleeve, size 14

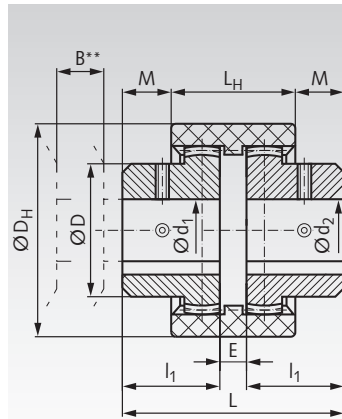

Position of set screws:
1 x on opposite of keyway, 1 x 90° displaced.

Product No. Hub	Size	Hub-bore d_1 / d_2	Product No. Sleeve	Torque normal Nm	Torque peak Nm	Speed max. min ⁻¹	D mm	D _H mm	B** mm	L ₁ mm	E mm	L mm	L _H mm	M mm	Weight Hub g	Weight Sleeve g
607 614 01*	14	5*	607 614 00	12	22	13000	25	41	14	20	9	49	37	6	80	25
607 614 08	14	8	607 614 00	12	22	13000	25	41	14	20	9	49	37	6	80	25
607 614 10	14	10	607 614 00	12	22	13000	25	41	14	20	9	49	37	6	80	25
607 614 12	14	12	607 614 00	12	22	13000	25	41	14	20	9	49	37	6	80	25
607 614 14	14	14	607 614 00	12	22	13000	25	41	14	20	9	49	37	6	80	25
607 619 01*	19	10*	607 619 00	18	30	11000	32	48	14	21	9	51	37	7	100	35
607 619 10	19	10	607 619 00	18	30	11000	32	48	14	21	9	51	37	7	100	35
607 619 12	19	12	607 619 00	18	30	11000	32	48	14	21	9	51	37	7	100	35
607 619 14	19	14	607 619 00	18	30	11000	32	48	14	21	9	51	37	7	100	35
607 619 15	19	15	607 619 00	18	30	11000	32	48	14	21	9	51	37	7	100	35
607 619 16	19	16	607 619 00	18	30	11000	32	48	14	21	9	51	37	7	100	35
607 619 19	19	19	607 619 00	18	30	11000	32	48	14	21	9	51	37	7	100	35
607 624 01*	24	10*	607 624 00	24	36	10000	36	52	13,5	21	13	55	40	7,5	150	35
607 624 12	24	12	607 624 00	24	36	10000	36	52	13,5	21	13	55	40	7,5	150	35
607 624 14	24	14	607 624 00	24	36	10000	36	52	13,5	21	13	55	40	7,5	150	35
607 624 15	24	15	607 624 00	24	36	10000	36	52	13,5	21	13	55	40	7,5	150	35
607 624 16	24	16	607 624 00	24	36	10000	36	52	13,5	21	13	55	40	7,5	150	35
607 624 19	24	19	607 624 00	24	36	10000	36	52	13,5	21	13	55	40	7,5	150	35
607 624 20	24	20	607 624 00	24	36	10000	36	52	13,5	21	13	55	40	7,5	150	35
607 624 24	24	24	607 624 00	24	36	10000	36	52	13,5	21	13	55	40	7,5	150	35

* Hubs pre-bored, without keyway, set screw threads and screws.

** B is the minimum dimension by which a machine part has to be moved in order to demount one of the coupled units in vertical direction.

General

When running the coupling in, the outer layer of the plastic teeth is worn away. The resulting flocculent abrasion is not to be interpreted as wear. Simple mounting - no maintenance - low weight - long service life.

Mounting

Align shafts, put feather keys into the shafts, push hubs onto the shafts. Push the hubs into the sleeve part, until you reach length L. The distance between the shafts should be measure E. Then the set screws have to be tightened firmly.

Curved-Tooth Gear Couplings BOS II made from Polyamide/Sintered Metal

Material: Sleeve part: polyamide 6.6.
Hub parts: sintered metal, black oxide finish.

Bore tolerance H7 with keyways DIN 6885/1 and set screws (2 screws per hub).

Hubs with * are pre-bored, without keyway and without set screw threads.

Axial displacement = max. ± 2 mm per hub.

Angular displacement = max. $\pm 1^\circ$ per hub.

Radial displacement = max. 0.3 mm at 1500 min⁻¹.

The permissible displacement values are dependent on power and speed.

Temperature range: -40°C to +80°C,
short time up to +120°C.

All 3 parts have to be ordered separately.

Other sizes and bores on request.

Ordering Details: e.g. for coupling Size 28,
with bore 14mm and bore 15mm:

1 Item Product No. 607 628 14 Hub, size 28, bore 14mm

1 Item Product No. 607 628 15 Hub, size 28, bore 15mm

1 Item Product No. 607 628 00 Sleeve, size 28

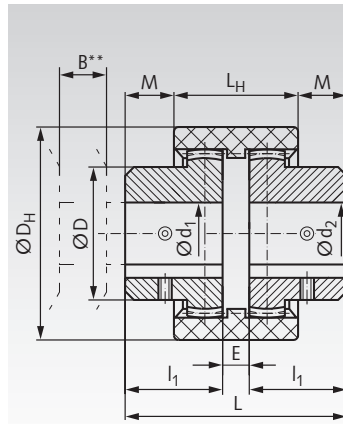

Position of set screws:

1 x on keyway, 1 x 90° displaced.

Product No. Hub	Size	Hub-bore d ₁ / d ₂	Product No. Sleeve	Torque normal Nm	Torque peak Nm	Speed max. min ⁻¹	D mm	D _H mm	B** mm	l ₁ mm	E mm	L mm	L _H mm	M mm	Weight Hub g	Weight Sleeve g
607 628 01*	28	6*	607 628 00	48	85	8000	44	67	16,5	35	13	83	46	18,5	380	70
607 628 14	28	14	607 628 00	48	85	8000	44	67	16,5	35	13	83	46	18,5	380	70
607 628 15	28	15	607 628 00	48	85	8000	44	67	16,5	35	13	83	46	18,5	380	70
607 628 16	28	16	607 628 00	48	85	8000	44	67	16,5	35	13	83	46	18,5	380	70
607 628 18	28	18	607 628 00	48	85	8000	44	67	16,5	35	13	83	46	18,5	380	70
607 628 19	28	19	607 628 00	48	85	8000	44	67	16,5	35	13	83	46	18,5	380	70
607 628 20	28	20	607 628 00	48	85	8000	44	67	16,5	35	13	83	46	18,5	380	70
607 628 22	28	22	607 628 00	48	85	8000	44	67	16,5	35	13	83	46	18,5	380	70
607 628 24	28	24	607 628 00	48	85	8000	44	67	16,5	35	13	83	46	18,5	380	70
607 628 25	28	25	607 628 00	48	85	8000	44	67	16,5	35	13	83	46	18,5	380	70
607 632 01*	32	12*	607 632 00	65	110	7300	50	76	17	35	13	83	47	18	500	90
607 632 19	32	19	607 632 00	65	110	7300	50	76	17	35	13	83	47	18	500	90
607 632 20	32	20	607 632 00	65	110	7300	50	76	17	35	13	83	47	18	500	90
607 632 22	32	22	607 632 00	65	110	7300	50	76	17	35	13	83	47	18	500	90
607 632 24	32	24	607 632 00	65	110	7300	50	76	17	35	13	83	47	18	500	90
607 632 25	32	25	607 632 00	65	110	7300	50	76	17	35	13	83	47	18	500	90
607 638 01*	38	12*	607 638 00	95	170	6500	58	84	17,5	35	13	83	48	17,5	650	105
607 638 19	38	19	607 638 00	95	170	6500	58	84	17,5	35	13	83	48	17,5	650	105
607 638 20	38	20	607 638 00	95	170	6500	58	84	17,5	35	13	83	48	17,5	650	105
607 638 22	38	22	607 638 00	95	170	6500	58	84	17,5	35	13	83	48	17,5	650	105
607 638 25	38	25	607 638 00	95	170	6500	58	84	17,5	35	13	83	48	17,5	650	105
607 638 30	38	30	607 638 00	95	170	6500	58	84	17,5	35	13	83	48	17,5	650	105
607 642 01*	42	12*	607 642 00	115	220	6200	68	93	17,5	38	14	90	49	20,5	930	130
607 642 25	42	25	607 642 00	115	220	6200	68	93	17,5	38	14	90	49	20,5	930	130
607 642 30	42	30	607 642 00	115	220	6200	68	93	17,5	38	14	90	49	20,5	930	130
607 642 35	42	35	607 642 00	115	220	6200	68	93	17,5	38	14	90	49	20,5	930	130
607 642 38	42	38	607 642 00	115	220	6200	68	93	17,5	38	14	90	49	20,5	930	130
607 648 01*	48	12*	607 648 00	160	300	5500	68	98	19	45	11	101	49	26	1100	160
607 648 30	48	30	607 648 00	160	300	5500	68	98	19	45	11	101	49	26	1100	160
607 648 35	48	35	607 648 00	160	300	5500	68	98	19	45	11	101	49	26	1100	160
607 648 38	48	38	607 648 00	160	300	5500	68	98	19	45	11	101	49	26	1100	160
607 648 40	48	40	607 648 00	160	300	5500	68	98	19	45	11	101	49	26	1100	160

* Hubs pre-bored, without keyway, set screw threads and screws.

** B is the minimum dimension by which a machine part has to be moved in order to demount one of the coupled units in vertical direction.

General

Simple mounting - no maintenance - long service life.
When running the coupling in, the outer layer of the plastic teeth is worn away. The resulting flocculent abrasion is not to be interpreted as wear.

Mounting

Align shafts, put feather keys into the shafts, push hubs onto the shafts. Push the hubs into the sleeve part, until you reach length L. The distance between the shafts should be measure E. Then the set screws have to be tightened firmly.